



Integrated asset management: a case study of technical and economic optimization of surface and well facilities

Arman Darvish Sarvestani¹ · Ali Moazami Goodarzi¹ · Ali Hadipour²

Received: 2 January 2019
© The Author(s) 2019

Abstract

Oil production could be increased by using optimization techniques in each stage of oil production system from field to production unit. However, the maximum profit will be obtained once integrated optimization of surface and subsurface components of the oil production system is implemented. In addition, when using high-tech equipment and facilities, an integrated study of well and surface facilities affects the economic benefits significantly. In this work, one of the Iranian brown fields (mature or declining production fields) was studied to find the best renovation plan with maximum profits. The base scenario was designed with four stages of separation, and the high-pressure gases from the first and the second separator were planned to be sold, while the low-pressure gases from subsequent stages were supposed to be flared. In this paper, two additional scenarios, namely separator optimization and full optimization, were proposed and 12 cases were defined. In the full optimization scenario, low-pressure gases were prevented from being flared. It was observed that by stopping the flaring systems, gas production rate increases as high as 20% and 150 to 200 MW power will be generated in all cases during the next 20 years. Finally, economic evaluation for all of the cases was done and different cases were compared in terms of incremental annual worth and payback period.

Keywords Separator · Electricity · Gas lift · Flare · NPV · Optimization

1 Introduction

Integrated asset management (IAM) is known as a more comprehensive solution than conventional approaches for field problems (Orangi et al. 2008). In contrast to the conventional approaches, integrated field study can help to obtain optimized field-wide production with lower capital costs (CAPEX). Exploration and Production (E & P) complex activities require different disciplines to be working together. Different disciplines have different aspects regarding varieties in their duties and expectations which make a field study a challenging and time consuming process (Cosentino 2001). Implementing IAM can reduce the

possible difficulties by connecting these disciplines and also can decrease the required engineering time. As a result, lower costs and higher engineering productivity would be obtained. Moreover, hardware and software integration can reduce the associated uncertainties and challenges during the field study (Cosentino 2001; Rubio et al. 2017). For instance, IAM could be used to connect reservoir, well and surface facilities to achieve maximum field profitability.

Due to the difficulties associated with multiphase flow transport, oil, gas and water phases are usually separated on the surface before being transported. Two- or three-phase separators must be used with respect to the composition of the well stream and the amount of water being produced with crude oil. Separator pressures are usually determined based on separator tests provided by fluid analysis (Bahadori et al. 2008; Ling et al. 2013; Sinnott and Towler 2009). But these separator tests are sometimes missed and determination of optimum separator conditions should be done by another method. Since separators are based on flash calculations, changing separator pressures may affect the liquid yields significantly (Kim et al. 2014; Kylling 2009; Mourad et al. 2009; Rakhma and Librawan 2015). So simulation of this process might be a

Edited by Xiu-Qin Zhu

✉ Arman Darvish Sarvestani
arman7d@gmail.com

¹ Oil & Gas Reservoir Engineering Department, Tarh-o-Palayesh Engineering Company, Tehran, Iran

² Process and Mechanical Group, Tarh-o-Palayesh Engineering Company, Tehran, Iran

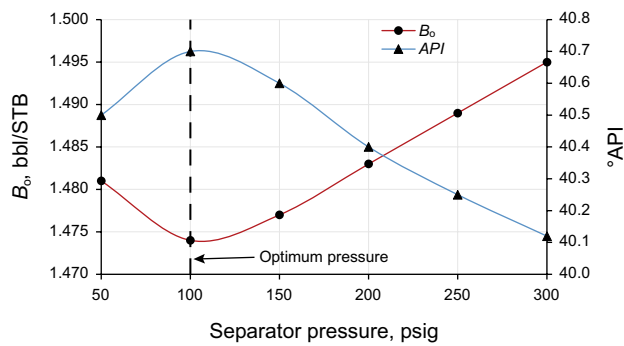

Fig. 1 Effect of separation pressure on different fluid parameters (Regenerated from (McCain 1990))

good way to find the optimum separator pressures. The oil formation volume factor (B_o), gas–oil ratio (GOR) and API of crude oil of the production unit depend on the separation pressure (McCain 1990). Figure 1 describes the effect of optimum separation conditions on oil recovery through a separator. Light components are vaporized at higher pressures, so the last separator contains the heaviest composition compared to the other separators (Danesh 1998). The maximum pressure of the first separator is usually limited by the wellhead pressure while the minimum feasible pressure (of the first separator) may depend on the required pressure for gas transportation through the gas flow line (Bahadori et al. 2008; Ling et al. 2013). The light gases obtained from the first and the second stages are usually used for natural gas liquid (NGL) plants, but the other gases (with low pressure) are generally flared. By using a complete gas recovery method, these gases, usually flared in conventional methods, could all be gathered and used for other applications such as electricity generation and improved oil recovery (IOR) or could be pressurized to inject into the gas pipelines (Rahimpour et al. 2012; Rahimpour and Jokar 2012). As a result, negative environmental effects of fossil fuel production would be reduced and lower amount of greenhouse gases would be emitted (Miles 2001; Mohanty et al. 2009; Rahimpour and Jokar 2012). Moreover, an additional source of energy would be available. Another point to mention is that the produced CO_2 (from an electricity generation plant) could be used for different IOR methods such as CO_2 injection (Gozalpour et al. 2005), CO_2 storage in coal bed methane (Pan et al. 2018) and fracking operations for unconventional resources (Li et al. 2018).

One of the first methods used to optimize the separator pressures is constant ratio method (Natco 1972). In this method, first, a ratio is calculated using production unit inlet pressure (or first separator pressure), stock tank pressure (atmospheric pressure) and the number of separation stages (Al-Jawad and Hassan 2010a; Ling et al. 2013; Natco 1972). The pressure of each separator could be calculated using the previous separator

pressure and calculated ratio. Related formulas are presented in Eq. (1) and Eq. (2):

$$\text{Ratio} = \left(\frac{P_{in}}{P_{ST}} \right)^{1/N} \quad (1)$$

$$P_i = \text{Ratio} \times P_{i-1} \quad (2)$$

where N , P_{in} and P_{ST} are the number of separation stages (excluding stock tank), inlet pressure of the first separator (psia) and stock tank pressure (atmospheric pressure), respectively. If the pressure of the first separator is the limiting parameter (instead of wellhead pressure), it would be used in the formula. This ratio shows the pressure ratio of sequential separators. The constant ratio method could be used as a first guess to calculate the optimum separator pressures.

It is reported that optimization of separation stages may result in incremental oil production (Bahadori et al. 2008; Boyer and O'Connell 2005; Ling et al. 2013). However, increased oil production due to this optimization may not be comparable with IOR or enhanced oil recovery (EOR) methods. But, the low cost of the optimization process magnifies its importance. Incremental oil production (compared to the constant ratio method) depends on different parameters such as crude oil properties and the number of separator stages (Al-Jawad and Hassan 2010b). Oil recovery increases as the number of separation stages increases. But, there is an optimum point at which adding to the number of separation stages does not increase the oil production significantly (Hassan 2004; Khamukhin and Nikolayev 2014). So the optimum number of separation stages must be calculated. At optimum separator conditions, GOR and B_o are minimized, while, the API value is maximized (Danesh 1998). It is believed that plus fraction splitting may also provide more accurate results compared to the case where a single plus fraction is used (Ling et al. 2013).

Flaring gases in the production unit is one of the reasons for carbon dioxide emissions which have a huge impact on global warming (Miles 2001). About 75% of the emissions of carbon dioxide come from the combustion of fossil fuels (IPCC 2001; Miles 2001). By optimizing the separator pressures, the amount of hydrocarbon gas from separation units would be decreased. It is in line with environmental rules. Preventing the associated gases being flared by collecting them could have huge impact on decreasing greenhouse gas emissions (Miles 2001). In addition, the collected gases are valuable resources which could be used for different options. These gases could be used for higher oil production by gas lifting technology or to be sold as a source of energy which results in greater income.

Artificial lift methods are widely used to produce oil from the wells which cannot flow naturally due to the lack of pressure (Brown 1977; Gilbert 1954; Senani et al. 2018).

Generally, down-hole pumps or gas lift systems are used to lift the oil from the wells to the surface (Hoffmann and Stanko 2017). Gas lift aids the production by decreasing the minimum required bottom-hole pressure of the well (Gilbert 1954; Shedid and Yakoot 2016). The pressure gradient of the well fluid is decreased as a result of injecting gas to the wellbore. High efficiency, ease of installation and compatibility with conventional well problems (like sand production) increase the tendency to implement gas lift systems (Brown 1977; Gilbert 1954; Shedid and Yakoot 2016). One of the main advantages of using a gas lift system is that the well performance can be predicted accurately (Soleimani 2017). Gas lift performance curves (Poettman and Carpenter 1952) can be used to predict gas lift performance in any well. Moreover, the optimum gas injection rate for each well may be calculated based on these curves (Poettman and Carpenter 1952; Shedid and Yakoot 2016). Commercial software is also capable of predicting well performance with and without implementing gas lift systems. A gas lift ring is a system with a constant input rate in which a cycle of gas is used to lift the liquids to the surface. The used gas would be produced from the wells and enters the production unit again. Since the gas injection rate for the proposed wells does not change, a constant amount of gas is required for lifting. Figure 2 shows the described cycle of gas lift system from production unit to the wells. To have a successful gas lift system design, the gas injection rate has proved to be the most important parameter (McKee 1988; Shedid and Yakoot 2016). However, water-cut, wellhead pressure, *GOR* and tubing roughness are also believed to be important factors in the performance of gas lift system (Shedid and Yakoot 2016). While, the impact of tubing roughness is less than the others (Shedid and Yakoot 2016).

Compression of produced gases and transporting them is another option to prevent carbon dioxide emissions as well as to increase the income (Rahimpour et al. 2012; Rahimpour and Jokar 2012). The increasing demand of natural gas (Global 2017) shows that an increase in natural gas production is necessary. So, the low-pressure gases could be pressurized and mixed with the high-pressure natural gas. Finally, it could be transported to the refineries.

Improving the performance of an Iranian oil field through the integrated optimization of surface, and well facilities was the aim of this study. Firstly, different numbers of separators are checked in terms of produced liquid in the stock tank. At the same time, the separator conditions are optimized and the results are compared with the current condition, where the conventional constant ratio method is implemented. Once the oil production is fully optimized and maximum oil recovery is obtained, separator gases were studied in order to stop flaring of the gases. Field efficiency improvement will be obtained by collecting and using the separator gases instead of burning them. Selling the compressed gas to refineries and electricity generation were assumed to be two efficient options here. Additionally, implementing a gas lift system was studied for both suggested options. These scenarios are evaluated here, and their results are fully discussed in this paper. Figure 3 describes the available options and proposed revisions to the current design of the field. Finally, economic profits of different cases are investigated to compare the results of these cases. The net present value (*NPV*) concept and payback period are the basis of the economic study. *NPV* shows the long-term profits of the project at the present time. In addition, the payback period shows the required time for capital investment to be returned.

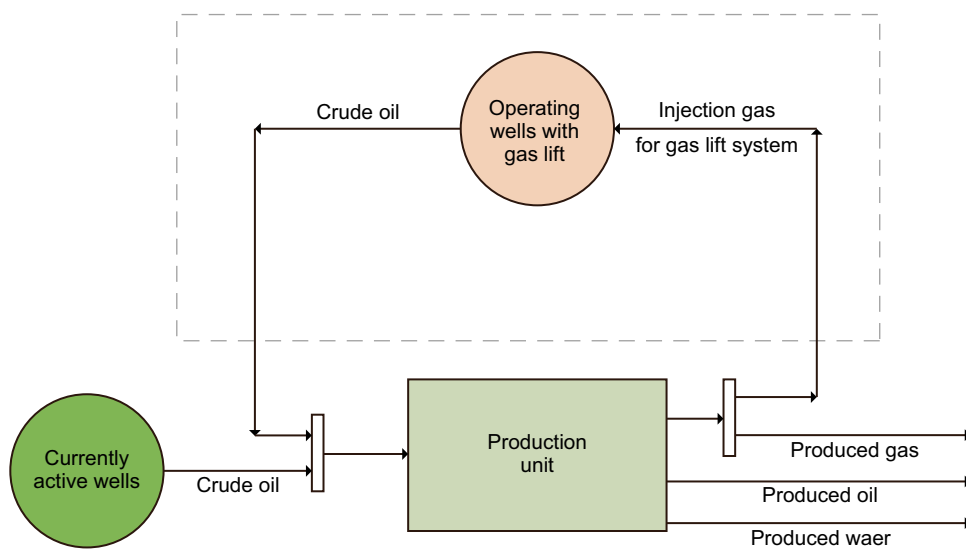

Fig. 2 A schematic of gas lift system

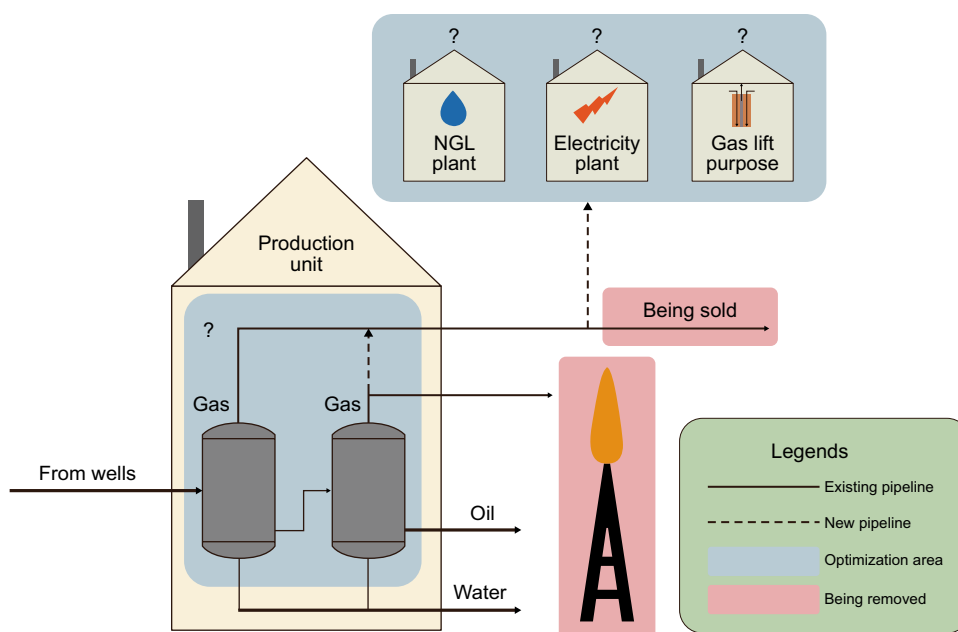

Fig. 3 Schematic of proposed options for field optimization

2 Process description

2.1 Optimization of separator pressures

Separation pressures and temperatures have a significant impact on the amount of produced stock tank oil. Separators are located in the surface. So setting the temperatures is not easy, and their temperatures are assumed to be a function of ambient temperature. In this project, the ambient summer and winter temperatures were assumed to be 50 °C and 10 °C, respectively. In-house code was developed for optimization of separator pressures. The algorithm of this code was based on trial and error. Simulation results proved that the optimum separator pressures would be different for different temperatures. So, separator pressures must be adjusted until the maximum volume of oil is obtained in the stock tank for each temperature individually. In this manner, firstly, the equation of state was tuned using experimental data such as differential liberation (DL), constant composition expansion (CCE) and viscosity tests (Danesh 1998). The composition of crude oil (without water) is presented in Table 1. The bubble pressure for this crude oil at 50 °C and 10 °C was 1911 psia and 1389 psia, respectively. Next, the constant ratio method was used for the initial estimate of separator pressures. Calculation of fluid parameters (including B_o , GOR and API) was based on Bahadori's method (Bahadori et al. 2008). The implemented optimization procedure is as follows:

Table 1 Composition of crude oil from one Iranian reservoir

Component	Mole, %
CO ₂	0.050
N ₂	0.150
H ₂ S	0.170
CH ₄	35.143
C ₂ H ₆	8.218
C ₃ H ₈	6.039
<i>i</i> -C ₄ H ₁₀	1.060
<i>n</i> -C ₄ H ₁₀	2.839
<i>i</i> -C ₅ H ₁₂	0.880
<i>n</i> -C ₅ H ₁₂	0.990
C ₆ H ₁₄	3.429
C ₇ H ₁₆	0.970
C ₈ H ₁₈	0.670
C ₉ H ₂₀	2.170
C ₁₀ H ₂₂	2.538
C ₁₁ H ₂₄	2.190
C ₁₂₊	32.494
Molecular weight C ₁₂₊	390.0
Specific gravity C ₁₂₊	0.9407

- (1) Change the pressure of the first separator and execute the flash calculations while the pressure of other separators remained constant at the previous step pressure. For the first step, the pressures of other separators should be equal to the initial estimate.

- (2) Estimate the oil formation volume factor (B_o), API gravity and gas–oil ratio (GOR) based on Bahadori’s method.
- (3) Select the optimum pressure of the first separator at which the GOR and B_o are minimized while the API gravity is maximized.
- (4) Change the second separator pressure while the pressure of other separators is constant. Note that the first separator pressure should be the value that determined in step 3.
- (5) Select the optimum pressure of the second separator based on the same criteria in step 3.
- (6) Repeat the same procedure for the third, fourth and n th separator to find the optimum pressure of each separator. Note that due to the operational limits (which will be discussed later), the pressure of the final separator (before stock tank) should not be less than 33 psia.
- (7) Once the optimum pressures for all of the separators are obtained, repeat steps 1 to 6 to determine the new optimum pressures.
- (8) Repeat this iterative procedure until the convergence criteria (no change in the pressure of separators) are met.

To optimize the separator pressures, different numbers of separation stages are considered for each temperature. As was discussed before, there is a constraint for the last separator pressure (before the stock tank) due to the control valves and other necessary instruments. So, the minimum pressure was considered to be 33 psia for the last separator in the simulations. Moreover, the stock tank liquid has an important parameter which also limits the design. Reid Vapor Pressure (RVP) is an important parameter for stock tank liquid which cannot be more than 8 and 12 psig for summer and winter, respectively. So, it should be checked for any design. If the RVP is greater than the mentioned limits, a stripper must be implemented to stabilize the produced oil. For all of the scenarios, the first and the second separators were designed to be three-phase separators, while the others were designed to be two-phase separators. However, the simulation results indicate that all of the water (even as high as 50% water-cut) would be separated in the first separator.

2.2 Gas compression for NGL units

A compression unit was simulated to compress and inject the lower pressure gases to the NGL pipeline, as well as high-pressure gases. In this manner, the following procedure is followed:

- (1) The stock tank (V-1) gas is compressed to the required pressure for being mixed with the previous separator’s gas.
- (2) The outlet gas from the compressor (C-1) is cooled through an air cooler (AC-1). This process reduced the

pressure of the gas stream almost 0.5 bar. So, it is taken into consideration in designing the compressor outlet pressure.

- (3) Next, a compressor scrubber (S-1) is implemented to ensure that the stream (entering the mixer and next compressor) is 100% vapor.
- (4) This vapor is mixed through a mixer (M-1) with the expelled gas from the last separator which has almost the same pressure.

This procedure is repeated for all of the separators, and all of the gases are gathered to be injected to the NGL feed pipeline. The simulated plant for a four-stage separation production unit in summer is illustrated in Fig. 4. The pressure must be higher than 45 bar to enter the NGL plant. So, the outlet pressure of last compressor was set to be almost 51 bar (747.2 psia). The pressure ratio of the compressor is less than 4:1, and the outlet temperature is controlled to be less than 140 °C. Also, the outlet temperature of air coolers was set to be about 5 °C higher than ambient temperature. The outlet temperature of air coolers for summer and winter was 55 °C and 15 °C, respectively.

2.3 Electricity generation

The principle of a power cycle is simple. Burning the gas to produce hot gases and passing it through a turbine would spin the blades of the turbine to generate power (Hodge 1955; Horlock 1987, 2013; Kerrebrock 1992; Walsh and Fletcher 2004). The Brayton cycle is one of the most efficient and simplest gas turbine cycles which could be used to generate electricity using hot gases. As shown in Fig. 5, the Brayton cycle consists of compressor, combustion chamber and gas turbine. With respect to this figure, atmospheric air enters the compressor and the pressure is increased to 21 bar. Then, the compressed air passes through a combustion chamber where it is blended with high-pressure natural gas and ignited. Next, the produced hot gases are directed to the gas turbine where they would expand to atmosphere pressure. The energy of the gas is converted into mechanical energy (by spinning the blades of the turbine) and electricity would be generated. The total efficiency of this system was 50.2% (Jansohn 2013). The pressurized air from the compressor and gas (fuel) from the production unit enter the combustion chamber and the following reactions presented in Table 2 take place in the reactor. Ideal combustion of all hydrocarbons from C_1 to C_{11} is assumed, and the effect of C_{12+} was assumed to be negligible (refer to Table 3).

Three scenarios were studied for electricity generation. In the base scenario (as discussed earlier), the produced gas from the first and second separator was gathered and used. In the next scenario (separator optimization), the separator conditions (number and pressure of separators) were optimized,

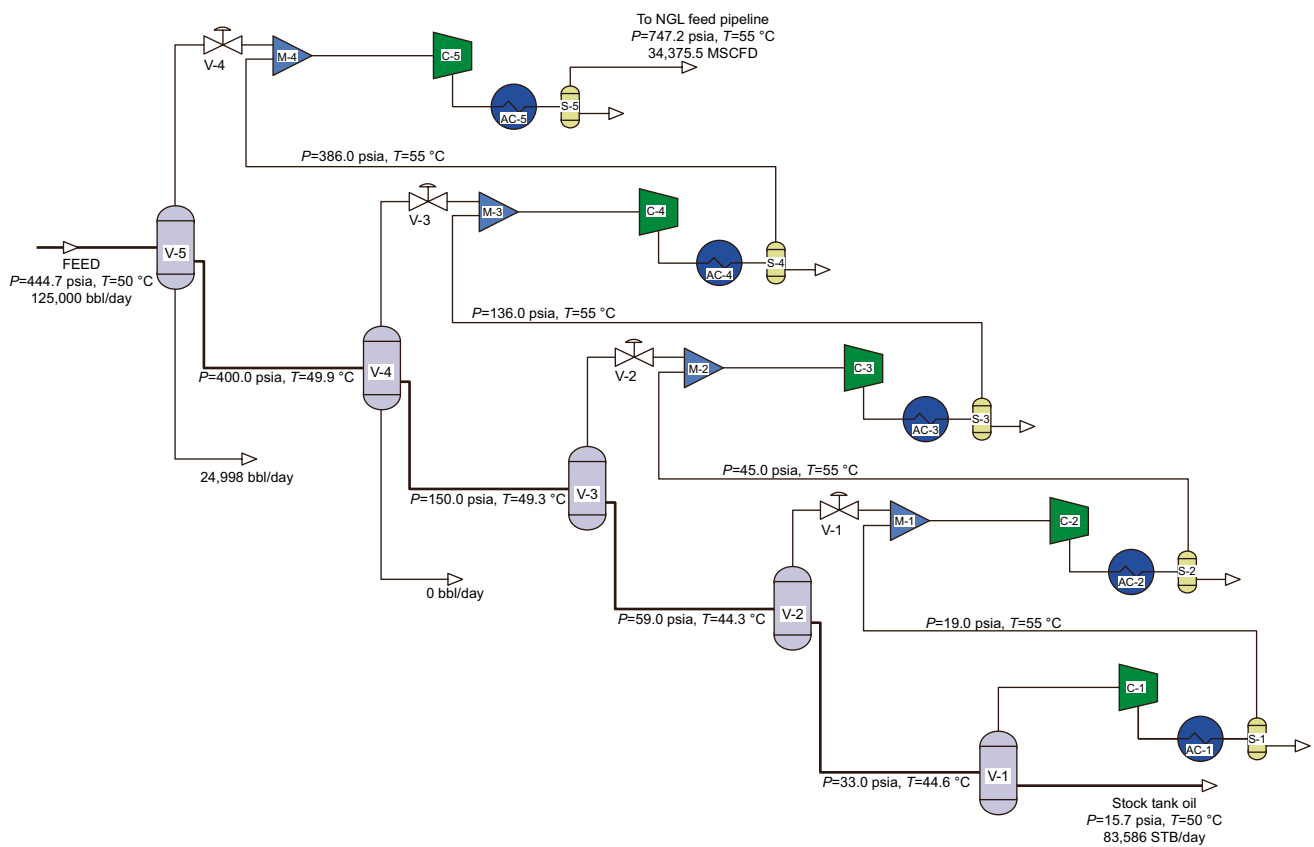

Fig. 4 Simulated plant for gas compression for NGL plant

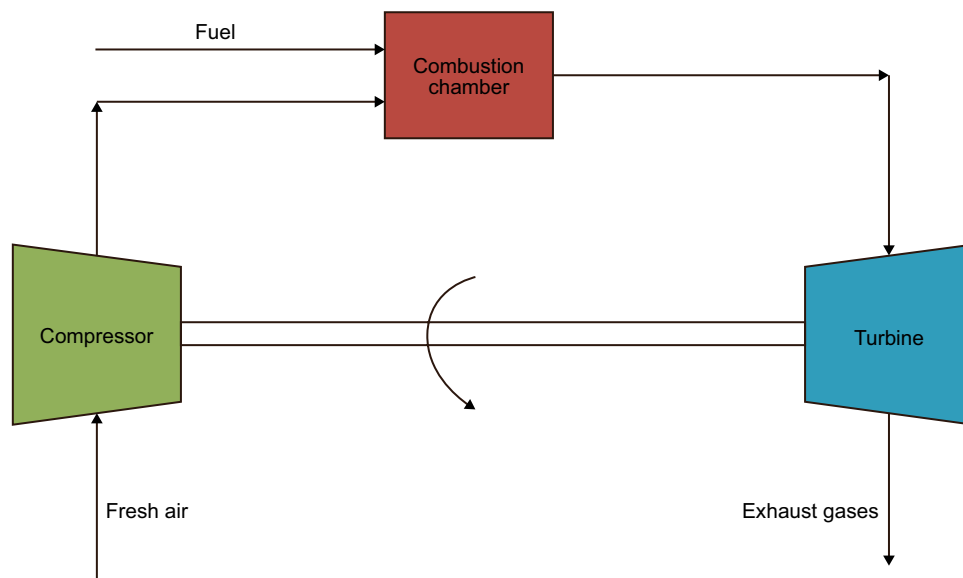

Fig. 5 Brayton cycle used for electricity generation

but the low-pressure gases (third and fourth separators with stock tank) were not compressed to be mixed with the high-pressure ones. In the third scenario (full optimization),

low-pressure gases were pressurized and added to the high-pressure gases. So, flaring the gases was completely stopped in the third scenario.

Table 2 Chemical reactions of gas combustion for electricity generation

Chemical reaction (combustion)	Heating energy, kJ/mol
$\text{CH}_4 + 2\text{O}_2 \leftrightarrow \text{CO}_2 + 2\text{H}_2\text{O}$	$\Delta H_{298\text{K}} = 803$
$\text{C}_2\text{H}_6 + \frac{7}{2}\text{O}_2 \leftrightarrow 2\text{CO}_2 + 3\text{H}_2\text{O}$	$\Delta H_{298\text{K}} = 1560$
$\text{C}_3\text{H}_8 + 5\text{O}_2 \leftrightarrow 3\text{CO}_2 + 4\text{H}_2\text{O}$	$\Delta H_{298\text{K}} = 2218$
$\text{C}_4\text{H}_{10} + \frac{13}{2}\text{O}_2 \leftrightarrow 4\text{CO}_2 + 5\text{H}_2\text{O}$	$\Delta H_{298\text{K}} = 2878$
$\text{C}_5\text{H}_{12} + 8\text{O}_2 \leftrightarrow 5\text{CO}_2 + 6\text{H}_2\text{O}$	$\Delta H_{298\text{K}} = 3509$
$\text{C}_6\text{H}_{14} + \frac{19}{2}\text{O}_2 \leftrightarrow 6\text{CO}_2 + 7\text{H}_2\text{O}$	$\Delta H_{298\text{K}} = 4180$
$\text{C}_7\text{H}_{16} + 11\text{O}_2 \leftrightarrow 7\text{CO}_2 + 8\text{H}_2\text{O}$	$\Delta H_{298\text{K}} = 4825$
$\text{C}_8\text{H}_{18} + \frac{25}{2}\text{O}_2 \leftrightarrow 8\text{CO}_2 + 9\text{H}_2\text{O}$	$\Delta H_{298\text{K}} = 5530$
$\text{C}_9\text{H}_{20} + 14\text{O}_2 \leftrightarrow 9\text{CO}_2 + 10\text{H}_2\text{O}$	$\Delta H_{298\text{K}} = 6125$
$\text{C}_{10}\text{H}_{22} + \frac{31}{2}\text{O}_2 \leftrightarrow 10\text{CO}_2 + 11\text{H}_2\text{O}$	$\Delta H_{298\text{K}} = 6779$
$\text{C}_{11}\text{H}_{24} + 17\text{O}_2 \leftrightarrow 11\text{CO}_2 + 12\text{H}_2\text{O}$	$\Delta H_{298\text{K}} = 7433$

Table 3 Volume and composition (mole percent) of the outlet gas stream with and without complete gas recovery

Component	Stages 1 and 2	All stages
CO ₂	0.096	0.095
N ₂	0.345	0.301
H ₂ S	0.188	0.269
CH ₄	77.570	70.480
C ₂ H ₆	13.450	15.770
C ₃ H ₈	5.670	8.680
<i>i</i> -C ₄ H ₁₀	0.578	0.980
<i>n</i> -C ₄ H ₁₀	1.180	2.050
<i>i</i> -C ₅ H ₁₂	0.185	0.325
<i>n</i> -C ₅ H ₁₂	0.167	0.292
C ₆ H ₁₄	0.228	0.375
C ₇ H ₁₆	0.025	0.037
C ₈ H ₁₈	0.007	0.009
C ₉ H ₂₀	0.009	0.009
C ₁₀ H ₂₂	0.004	0.004
C ₁₁ H ₂₄	0.002	0.001
C ₁₂₊	0.000	0.000
Total	100.000	100.000
Production rate, MSCFD	29,875.6	34,375.5

2.4 Gas lift

Since the field was known to be a brown one, there were nine wells which were facing lifting problems. The oil production rate of these wells had decreased (or ceased) due to lack of pressure. So, it was proposed that using available sources of gas in both gas compression and electricity generation options might be a solution to increase the production rate. A gas lift ring was designed to provide the required amount

of gas for these wells. Each well was supplied by this ring, and the required amount of gas was evaluated by simulation of each well individually. The effect of different water-cuts (0%, 20% and 50%) on gas lift performance was studied. The well schematic for one of these wells is presented in panel “a” of Fig. 6. As can be observed, the well is not deviated. Gas enters the annulus and lifts the oil to the surface through tubing. Some valves (V-1, V-2 and V-3) are located in the well for unloading purpose (if needed), but a single-point injection design (through a gas lift valve) was implemented for continuous gas lifting. Panel “b” of Fig. 6 shows the performance of unloading valves for the same well. Unloading valves would aid the liquid being produced once the well is not flowing. Simulation of gas lift systems was done using nodal analysis software.

3 Results and discussion

3.1 Optimization of separator pressures

As can be predicted, a different number of separator stages led to different amounts of recovered oil in the stock tank. Increasing the number of separator stages resulted in higher oil in the stock tank. Figure 7 illustrates this effect very well. In this figure, the results of both the optimum number of separator stages and the conventional constant ratio method are presented. The number of separation stages was tested for two, three, four, five and six stages of separation (including stock tank).

It was observed that the effect of optimization of separation conditions could be compared to increasing the number of separation stages. For example, recovered oil in stock tank in a four-stage separation design with constant ratio method is 83,379 bbl. For this case, optimization of the separator conditions leads to an additional 52 bbl of oil in stock tank, while, increasing the number of separator stages could recover an additional 89 bbl of oil. Since the optimization of separator conditions is almost free of charge in terms of operational design, the value of optimization will be much more attractive. Moreover, the effect of adding an extra separator stage decreases as the number of separator stages increases. For instance, increasing the number of separators from three to four and from four to five leads to additional 177 and 89 barrels of oil, respectively. Although the incremental oil recovery is not significant compared to the oil production rate (0.3%), the simulation results show that optimization of separation stages is important.

As discussed before, under optimum conditions, *GOR* and *B_o* are minimum while *API* is maximum. The values of *B_o* and *API* are presented in Fig. 8 while *GOR* is presented in

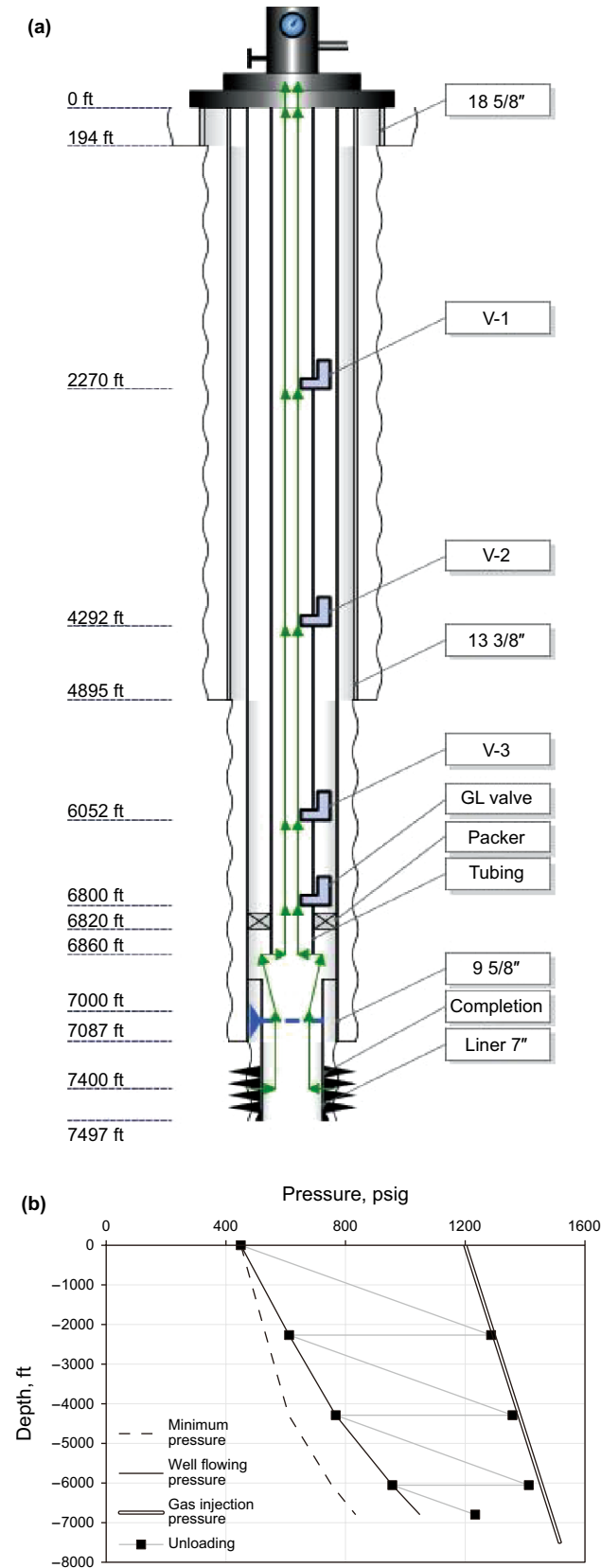

Fig. 6 a A schematic of wells and completions considered for gas lift, b well performance by implementing gas lift system (continuous gas lift with unloading valves)

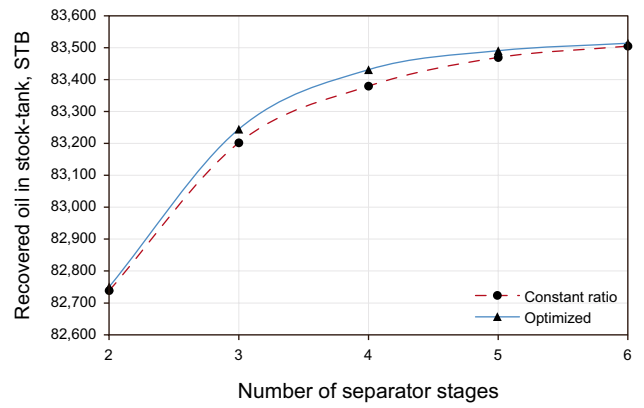

Fig. 7 Oil recovery versus the number of separation stages for both methods (feed = 100,000 bbl/day and 0% water-cut)

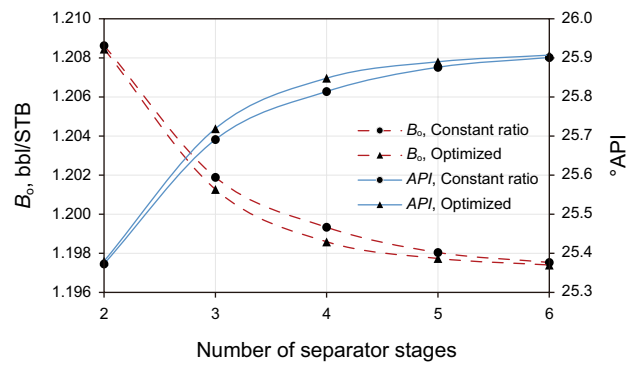

Fig. 8 API and B_o for both constant ratio and optimized method in different separation stages

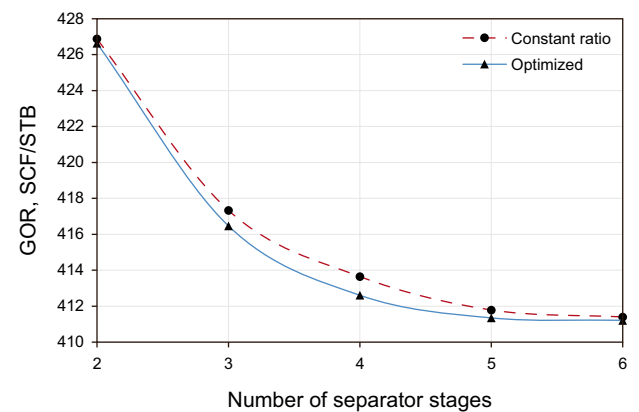

Fig. 9 GOR for both constant ratio and optimized method in different separation stages

Fig. 9. In comparison with the base case, where a four-stage separator design was implemented, an incremental amount of additional oil could be produced in the stock tank if the proposed optimization method is used.

The obtained pressures yield the maximum amount of stock tank liquid. This procedure was done by using optimization code to ease the calculations. In the base scenario, three separators and a stock tank were considered. For both the summer and winter conditions, the operational pressures of the vessels were supposed to be 400, 136, 46 and 15.7 psia, respectively. The results of base scenario are presented in Table 4. Our simulation results showed that different separator pressures for summer and winter should be proposed. Also, it was confirmed that four-stage separation (excluding stock tank) would be more efficient than the others. For each season, the optimum pressure of separators for different amounts of water-cut (0%, 20% and 50%) was calculated. Table 5 presents the optimum pressure of separators for 0%, 20% and 50% water-cut. The current average water-cut of the field was reported to be 20% which will increase to 50% during next 20 years. Comparing the results of these tables shows that the incremental oil production ranges from 64 to 248 barrels per day. As water-cut increases, the ratio of oil volume to total volume decreases and crude oil production rate decreases. As a result, the gas production rate decreases too. However, gas composition would not be changed significantly. The compositions of the outlet gas stream for different scenarios are presented in Table 3.

Table 4 Oil recovery for the base scenario of production unit (constant ratio method) for different water-cuts

Water-cut, %	Temperature, °C	Stock tank oil, STB/D
0	50	104,190.7
	10	106,762.2
20	50	83,338.3
	10	85,400.5
50	50	52,082.3
	10	53,371.0

Table 5 Longtime optimum separator condition for different temperatures and water-cuts

Water-cut, %	Temperature, °C	Pressure, psia					Stock tank oil, STB/D
		Sep. #1	Sep. #2	Sep. #3	Sep. #4	Stock tank	
0	50	400	148	59	33	15.7	104,302.6
	10	393	157	62	33	15.7	106,887.3
20	50	400	150	59	33	15.7	83,586.7
	10	400	159	62	33	15.7	85,501.7
50	50	400	144	59	33	15.7	52,238.7
	10	400	158	62	33	15.7	53,434.7

3.2 Gas compression for NGL units

For the base scenario (before our study), it was planned that only the gases from the first and second separator would be used for NGL plants. But by implementing the separation optimization method described in the previous section, the expelled gases from the first and the second separator would be used, but the gases from subsequent separators would be flared. In the third scenario, full optimization (maximum oil and gas recovery), all the gases would be gathered and flaring the gases would be stopped. The gas production rate for each condition is presented in Table 6. Optimizing the separator conditions resulted in a slight reduction in the gas production rate. Since the pressure difference between the first and second separator was decreased, the gas production rate of the first and second separator was reduced. But, by gathering the separated gas from all of the separators (full optimization), gas production rate was increased compared to the previous scenarios.

Table 6 Gas production rate for base and optimum scenarios in summer and winter with different water-cuts

Water-cut, %	Temperature, °C	Gas production rate, MSCFD		
		Base	Separation optimization	Full optimization
0	50	37,692.0	37,282.1	42,962.9
	10	33,678.1	32,870.8	39,091.6
20	50	30,201.9	29,875.6	34,405.4
	10	26,910.6	26,262.6	31,239.9
50	50	18,754.2	18,606.0	21,376.7
	10	16,728.0	16,430.7	19,429.8

3.3 Electricity generation

Converting the production unit gas to electricity is another method to increase the income of the field. Electrical energy is widely used and electricity usage is increasing due to the revolution in technology. Also, using electricity is cleaner compared to direct use of fossil fuels. In addition, maintaining the fuels in gas form is cheaper than in liquid form (Rahimpour and Jokar 2012).

Since the volume and composition of produced gas is not the same for different scenarios, the amount of power generated may differ significantly. Also, effect of

Table 7 Electricity power generation for different scenarios in summer and winter with different water-cuts

Water-cut, %	Temperature, °C	Electricity power, MW		
		Base	Separator optimization	Full optimization
0	50	271.4	267.4	340.2
	10	220.3	213.8	280.4
20	50	216.9	213.6	269.2
	10	176.1	170.7	224.5
50	50	134.9	133.6	167.6
	10	109.6	106.9	140.4

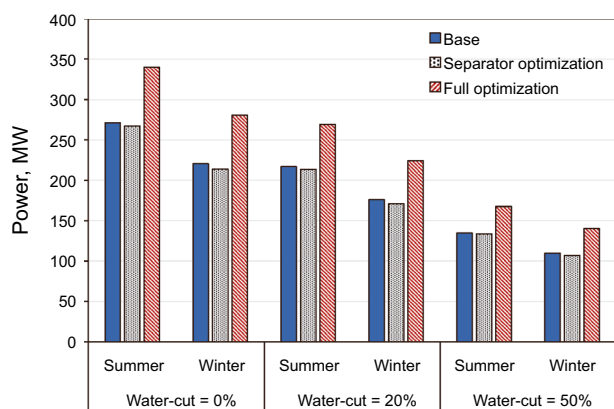

Fig. 10 Electricity power generation in different conditions

Table 8 Liquid production rate of proposed wells after gas lifting

Well no.	Liquid production rate, STB/D										Oil production rate, STB/D	
	1	2	3	4	5	6	7	8	9	Total		
Water-cut												
0%	2543.9	2384.6	2290.2	2819.9	1508.7	2360.1	1641.3	2053.8	1805.0	19,407.5	19,407.5	
20%	2569.0	2412.1	2311.7	2876.1	1542.4	2412.4	1675.3	2096.4	1842.3	19,737.7	15,790.2	
50%	2549.6	2389.9	2313.4	2790.8	1575.0	2444.7	1710.2	2136.2	1880.4	19,790.2	9895.1	

temperature and water-cut on power generation was studied. For instance, generated electricity in summer with 20% water-cut for base scenario and optimum scenario is 216.9 MW and 269.2 MW, respectively. Table 7 illustrates the results of electricity generation. As the water-cut increases, the oil and gas production rate decreases. So, generated electricity power decreases too. Electricity power for 0%, 20% and 50% water-cut in winter for optimum scenario are 280.4, 224.5 and 140.4 MW, respectively. Figure 10 shows the results, graphically. Full optimization of oil and gas recovery system results in the highest amount of generated electricity. As a result of separator optimization, oil recovery increases (*GOR* decreases). So, gas production rate and electricity generation would decrease. But by implementing optimized gas recovery (compressing the low-pressure gases), the gas production rate would be increased significantly. A sharp increase in electricity generation for fully optimized scenarios shows this very well.

3.4 Gas lift

The produced oil from proposed wells (with gas lift) is presented in Table 8. The liquid production rate is designed to be almost the same for different water-cuts. But the oil production rate for 0%, 20% and 50% water-cut is 19,407.5, 15,790.2 and 9895.1 STB/D, respectively. The depth of the wells ranges from 7497 to 8255 ft. Regardless of the ambient temperature and water-cut, 30 MMSCFD of gas is injected into the gas lift ring. The simulation results showed that this value is more than the required amount of gas for any condition. The gas injection rate for the wells ranges from 2.2 to 3 MMSCFD per well. As water-cut increases, more gas would be required to lift the liquid up to the surface. Minimum wellhead pressure of the wells was designed to be 450 psia. So, the produced crude by gas lift could be entered to the first separator.

Tables 9, 10 and 11 report the impact of implementing the gas lift system for the base scenario, separator optimization and full optimization, respectively. Comparison of Table 4 with these tables illustrates that oil recovery for all of the cases was increased significantly. For example,

Table 9 Oil, gas and electricity production by using gas lift system for base scenario

Water-cut, %	Temperature, °C	Oil production rate, STB/D	Gas production rate, MSCFD	Electricity generation, MW
0	50	120,211.2	43,212.5	309.2
	10	123,695.4	37,449.5	246.0
20	50	93,890.6	33,747.4	240.8
	10	96,598.5	29,181.0	192.1
50	50	56,227.2	20,185.0	143.9
	10	58,038.9	16,724.5	110.6

Table 10 Oil, gas and electricity production by using gas lift system for separator optimization scenario

Water-cut, %	Temperature, °C	Oil production rate, STB/D	Gas production rate, MSCFD	Electricity generation, MW
0	50	120,548.4	42,787.9	305.2
	10	123,898.6	36,578.5	239.1
20	50	94,047.8	33,362.7	237.3
	10	96,759.2	28,413.8	186.2
50	50	56,309.1	20,047.3	142.7
	10	58,139.7	16,260.8	107.1

Table 11 Oil, gas and electricity production by using gas lift system for full optimization scenario

Water-cut, %	Temperature, °C	Oil production rate, STB/D	Gas production rate, MSCFD	Electricity generation, MW
0	50	120,598.5	49,620.5	379.5
	10	123,961.0	44,724.9	312.8
20	50	94,081.2	38,794.1	294.0
	10	96,796.2	35,025.4	244.2
50	50	56,326.7	23,562.0	174.0
	10	58,162.3	20,399.8	141.4

recovered oil for the base case with 20% water-cut at 10 °C with and without implementing gas lift was 96,598.5 and 85,400.5 STB/D, respectively. Moreover, it could be concluded that amount of produced gas and generated electricity would be increased as well (refer to Table 6 and Table 7).

For instance, generated electricity in full optimization scenario with 20% water-cut at 50 °C for the case with and without using gas lift was 294.0 and 269.2 MW, respectively. The impacts of implementing gas lift on different scenarios are presented separately.

3.4.1 Impact of gas lift on oil recovery

The gas lift system was implemented to increase the oil production rate of the field. As mentioned before, it is a brown field and oil production from some of the existing wells had decreased or ceased. Our results showed that using the gas lift system increases the oil production rate significantly. The tubing performance of the well would be improved as a result of pressure gradient reduction. As a result, inactive wells could be activated and the field oil production rate would be increased. Figure 11 shows the positive impact of the gas lift system on tubing performance for one of the proposed wells. As can be observed in panel “a” of Fig. 11, oil cannot flow naturally (IPR, inflow performance relationship, and TPR, tubing performance relationship, curves do not intersect). But as shown in panel “b” of Fig. 11, oil would be produced as a result of implementing the gas lift system. Decreasing the fluid pressure gradient reduces the required minimum bottom-hole pressure of the well. Consequently, the well would become active and oil would be produced.

Incrementally produced oil enters the production unit and would be processed as described before. Since the production unit inlet crude rate is increased, a greater amount of oil would be produced. Figure 12 shows the impact of the gas lift system on the oil production rate for different scenarios and different water-cuts. For example, the oil production rates for the full optimization scenario without gas lift in summer and winter are 83,586.7 and 85,501.7 STB/D, respectively. By implementing the gas lift system, the oil production rate would be increased to 94,081.2 and 96,796.2 STB/D for summer and winter, respectively. The increased oil production rate (with gas lift) for different scenarios and water-cuts are between 7.8% and 16.0%.

3.4.2 Impact of gas lift on gas recovery

Using the gas lift system affects the field gas recovery, too. As mentioned before, 30 MMSCFD of associated gas is injected into the gas lift ring. Some of the injected gas would be dissolved in the oil and bring the liquid to the surface. Moreover, an excess amount of gas is injected to ensure approximately the required injection pressure. Simulation results showed that required amount of gas for different scenarios and different conditions ranges from 21.2 MMSCF to 25.6 MMSCF per day.

The gas production rate after using the gas lift system would be increased for all cases. Figure 13 represents the gas production rate for each scenario before and after implementing gas lift system. The amount of produced gas in summer is higher than that for winter. It was observed that ambient temperature could affect the amount of produced gas, significantly. As temperature decreases, the ratio of gas to liquid (K-value) would be decreased and a lower amount

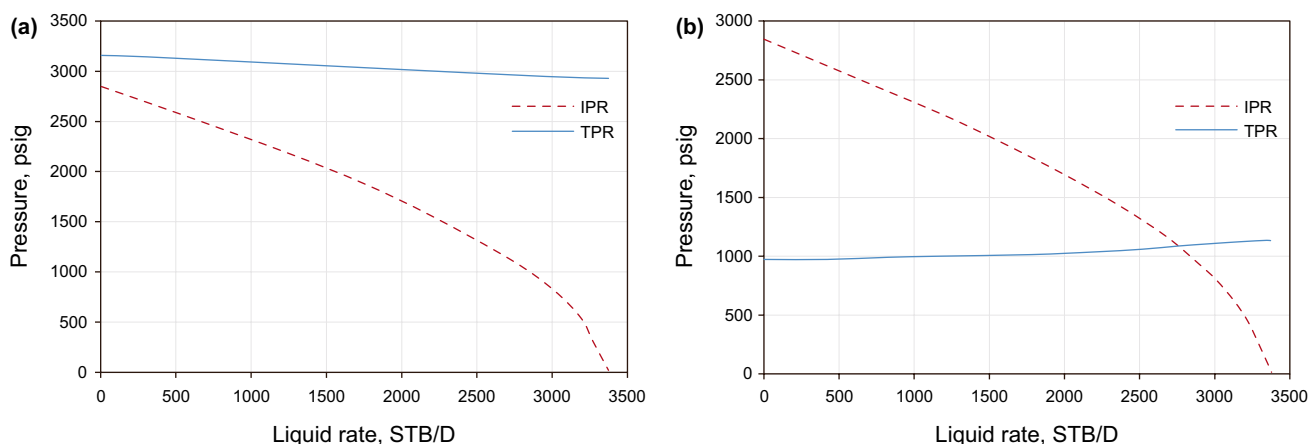

Fig. 11 Impact of gas lift system on oil production. a Before implementing gas lift system, b after implementing gas lift system

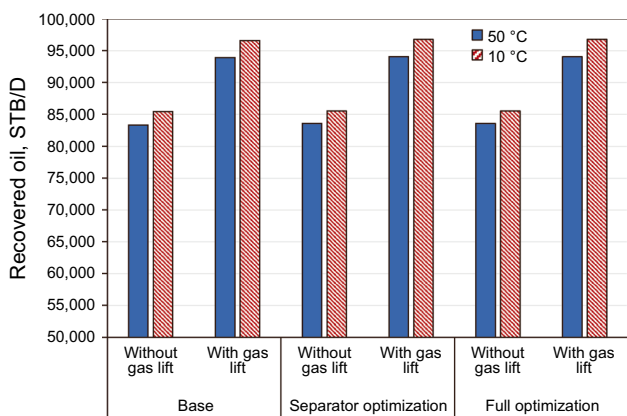

Fig. 12 Impact of gas lift system on recovered oil for different scenarios with 20% water-cut

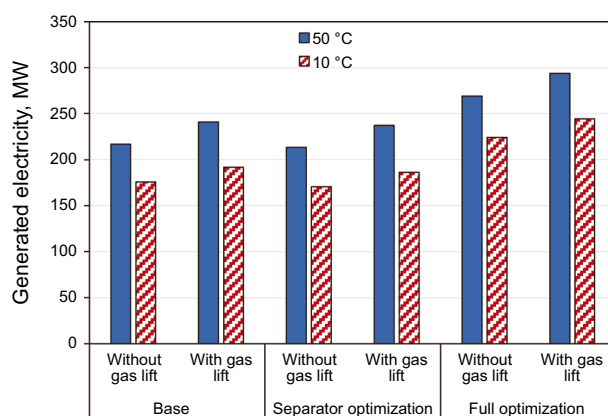

Fig. 14 Impact of gas lift on the amount of generated electricity for different scenarios with 20% water-cut

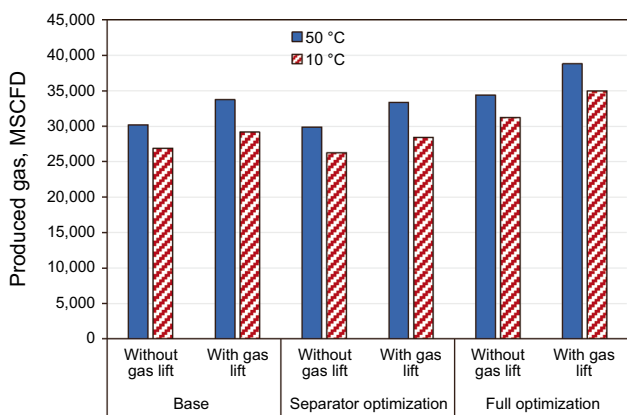

Fig. 13 Impact of gas lift on the amount of compressed gas for different scenarios with 20% water-cut

of gas would be produced. For instance, the gas production rates for fully optimized scenario in summer and winter were 38,794.1 and 35,025.4 MSCFD, respectively. The gas

production rate for the base case with and without gas lift system in summer would be 33,747.4 and 30,201.9 MSCFD, respectively. Optimization of separator conditions results in a slight decrease in the gas production rate. But by full optimization of oil and gas recovery, the amount of produced gas would be increased. For instance, the gas production rate with the gas lift system in summer for two scenarios of separator optimization and full optimization were 33,362.7 and 38,794.1 MSCFD, respectively. So, changes in the gas production rate for these two cases would be -384.7 and $+5046.7$ MSCFD, respectively. As presented in Tables 9, 10 and 11, the gas production rates for all of the studied cases were increased by using the gas lift system. The economic benefits of different scenarios will be discussed later.

3.4.3 Impact of gas lift on electricity generation

Generally, the amount of electricity generation depends on gas composition and gas production rate. Since associated

gas is used for the gas lift system, gas composition does not affect the electricity generation compared to the gas production rate. So electricity generation would be improved by using gas lift. Figure 14 illustrates the generated electricity for different cases with 20% water-cut. Comparison of Figs. 13 and 14 shows the dependency of generated electricity on the amount of produced gas very well. Moreover, differences in electricity generation in summer and winter can be observed in this figure. For example, generated electricity in summer and winter for the full optimization scenario without the gas lift system would be 269.2 and 224.5 MW, respectively. By implementing the gas lift system, a sharp increase in electricity generation would be obtained. The amount of generated power for the mentioned scenarios with gas lift was 294.0 and 244.2 MW, respectively. This figure shows that gas recovery optimization greatly enhances electricity generation. Finally, it was observed that full optimization of produced gases increases the electricity generation between 21.9% and 32.0% in different scenarios.

4 Economic evaluation

As discussed before, three scenarios were studied and compared in terms of oil, gas and electricity production. Moreover, different cases were defined for each scenario. Selling the produced gas, using the gas for electricity generation and adding the gas lift system were the feasible options. Annual worth and payback period are used to compare different cases in terms of economic evaluation. Regarding this, income was determined with respect to oil, gas and electricity production for different cases. Table 12 illustrates the current prices and costs for each product per unit. The prices would not be constant during the next 20 years, so it is assumed that they would be increased annually (EIA 2017). Current gas price has been considered to be 2.80 \$ per million BTU.

NPV is widely used in oil and gas industries to convert the long-term profits of the project to the current worth. Equation (3) shows the NPV formula for 20 years. The nominator of this equation represents the net cash flow of the project, while the denominator illustrates the time value of money.

$$NPV = \sum_{n=1}^{20} \frac{(\text{Positive cash flows of the } n\text{th year} - \text{Negative cash flows of the } n\text{th year})}{(1 + i)^n} \tag{3}$$

where *i* is the interest rate and *n* is the time (years) at which cash flows are supposed to be calculated. Positive and negative cash flows are total incomes and expenditures of the project, respectively.

As presented in Eq. (4), to convert the total profits of the project to annual worth, a conversion factor should be

Table 12 Production costs and selling prices of different products

	Oil	Gas	Electricity
Operating & maintenance (O & M)	7.0 \$/STB	0.53 \$/MSCF	0.0047 \$/kWh
Selling price	60.00 \$/STB	3.17 \$/MSCF	0.24 \$/kWh

multiplied to the total NPV. This coefficient depends on the duration of the project and interest rate. For a 20-year project with a 10% interest rate, it would be 0.117. Equation (5) defines the payback period which is the required time for the capital investment to be returned. As rate of return (ROR) increases, the payback period decreases.

$$\text{Annual worth} = NPV \times \left(\frac{i(1 + i)^n}{(1 + i)^n - 1} \right) \tag{4}$$

$$\text{Payback period} = \text{Capital costs} / \text{Annual worth} \tag{5}$$

Finally, 12 cases were defined based on the three scenarios and available options. Case 1 was the base case. In case 2–4, no change was made on separator configuration but different options were used for each case. Using the gas lift system, electricity generation plant or both of them together are the available options. The same procedure has been followed for separation optimization (case 5–8) and full optimization (case 9–12) scenarios. Estimation of capital and operating expenditures for each case were provided by Tarh-o-Palayesh Engineering Company. Estimated CAPEX for each case is presented in Table 13. Total CAPEX of the base case was estimated to be 54 million USD. Other cases need a greater amount of money to be invested. For all of the studied cases, overhaul periods (60 days per each 5 year) have been assumed. Operating expenditures (OPEX) for each case could be calculated (refer to Table 12). Oil and gas production costs have been considered for all of the cases. But other costs (such as electricity generation or gas lift) depend on the specific case design. O & M, operations and maintenance, cost for gas lift is assumed to be 0.35 \$/MSCF.

The base case was suggested by the client as a renovation plan for this field. Twenty-year NPV and annual worth of the base case were 15.6 and 1.8 billion USD, respectively. Other

studied scenarios were compared to the base case in terms of additional costs and incremental profits. In this manner, incremental annual worth and payback periods for different scenarios are calculated and compared to find the best cases. Figure 15 shows the results of incremental capital costs of different cases. As can be observed, the incremental costs

Table 13 Details of capital investment for different scenarios

Case ID	Scenario(s)	Costs, million \$					TOTAL CAPEX
		Production unit	Compression unit	Electricity plant	Gas Lift system	Indirect	
1	Base	6	28	–	–	20	54
2	Base + gas lift	7	35	–	36	22	100
3	Base + electricity	6	28	96	–	35	165
4	Base + electricity + gas lift	7	35	103	–	37	218
5	Separator optimization	8	28	–	–	22	58
6	Separator optimization + gas lift	9	35	–	36	24	104
7	Separator optimization + electricity	8	28	94	–	36	166
8	Separator optimization + electricity + gas lift	9	35	101	36	40	221
9	Full optimization	8	36	–	–	25	69
10	Full optimization + gas lift	9	45	–	36	28	118
11	Full optimization + electricity	8	36	120	–	39	203
12	Full optimization + electricity + gas lift	9	45	128	36	41	259

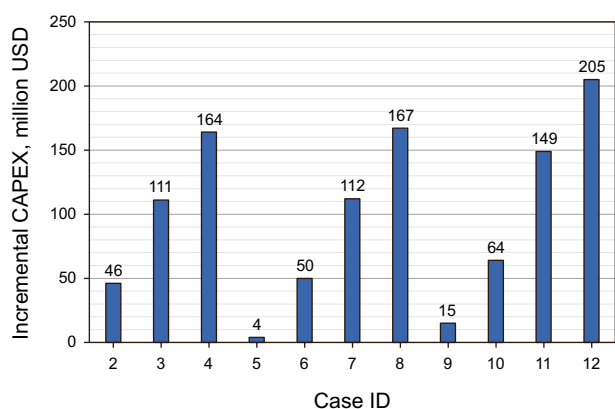

Fig. 15 Comparison of incremental CAPEX for different cases

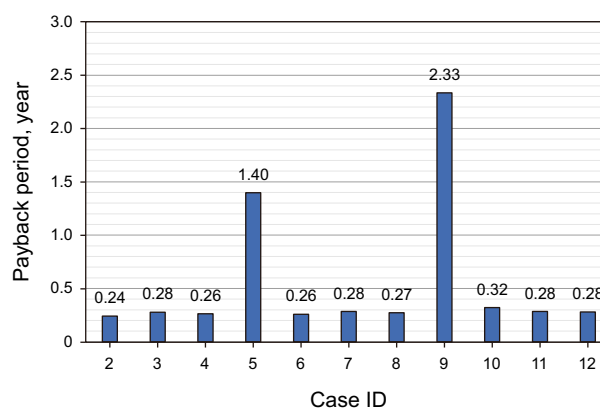

Fig. 17 Comparison of payback period for different cases

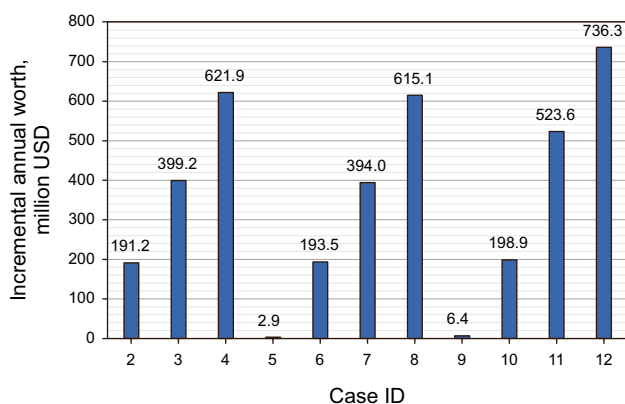

Fig. 16 Comparison of incremental annual worth for different cases

have a wide range and vary from 4 to 205 million USD. If the initial funds are not limited, incremental annual worth

should be considered as the selection criterion. But, if the initial funding is limited, both incremental capital costs and incremental annual worth should be considered.

Results of incremental annual worth are shown in Fig. 16. The maximum incremental annual worth was obtained from case 12 where the full optimization scenario has implemented with the gas lift system and electricity plant. But this case has the highest incremental CAPEX too. So, another parameter (payback period) is introduced and used to compare the results more accurately. Payback period of the studied cases is presented in Fig. 17. It was observed that the minimum and maximum payback periods of different cases are 0.24 and 2.33 years, respectively. Consequently, installing the gas lift system accelerates the return rate of the invested money. Comparison of case 9 and 10 shows the effect of adding the gas lift system. In case 10, the payback period has a significant decrease compared to case 9. The same comparison could be done

between cases 5 and 6. Additionally, using the compressed gas for electricity generation leads to a sharp increase in the incremental annual worth. In Fig. 16, comparison of case 11 and case 12 shows the impact of electricity generation on incremental annual worth. The incremental annual worth has increased from 524 to 736 million USD as a result of using compressed gas for electricity generation.

If gas lift or electricity generation is not implemented (case 5 and case 9), the incremental annual worth increases less than incremental CAPEX. So, the payback period would increase. Moreover, it was observed that impact of electricity generation is greater than using the gas lift system. On the other hand, electricity generation requires higher investment. As it can be observed in Fig. 15, incremental CAPEX of case 3 is almost 55 million USD more than the case 2. The same trend could be observed for cases 6 and 7.

Figure 16 shows that if the initial funding is not limited, case 12 is the best case in terms of annual profit. In this case, both the oil and gas recovery systems are optimized and compressed gas is used for power generation. Although the highest incremental capital cost (205 million USD) is for this case, the payback period is almost 100 days and incremental annual profit of this case would be 736 million USD.

5 Conclusions

In this paper, the integrated asset management technique was implemented to optimize the surface and well facilities of an oil field. Optimization of the production unit and using associated gases for different applications (compression, electricity generation and gas lift) were evaluated through simulation of 12 different scenarios. Both technical and economic terms were considered to compare the results. The following conclusions were obtained by using the IAM technique:

- By using the integrated asset management technique, different components of oil & gas fields are studied at the same time. Consequently, the long-term efficiency of the field will be increased and misunderstanding between different disciplines will be avoided. Moreover, this technique could be employed for a group of fields as a single package to increase the benefits and reduce the costs. Consequently, implementing the IAM technique overcomes the possible challenges of current step-by-step study of the fields, which is what is normally followed in the most companies. So, the governments (or other regulators) should review their policy about the procedure of studying hydrocarbon resources.
- Although the incremental oil production by separator optimization might be small, the effect of separator pressure optimization might be as high as adding to the number of separator stages.

- Flaring the gas leads to negative environmental impacts and economic loss. Once the flaring was stopped, a greater amount of gas (as high as 20% in case 10) would be available to be sold. In case 10, almost 4.9 MMSCFD additional gas was produced compared to case 6 during the next 20 years. Also, this additional gas could be used for other applications.
- For each case, as the temperature varies between summer and winter, oil and gas production in these conditions differs significantly. The higher the temperature, the higher the gas to liquid ratio. So, a higher amount of gas would be produced in summer. As a result, for the cases, where the produced gas would be used for electricity generation, a higher amount of power be produced in summer.
- The gas lift system was concluded to be very effective to increase the economic benefits of the field. A substantial increase in oil production was observed by implementing gas lift for inactive wells. Associated gas was the source of gas for lifting purposes. A 30,000 MSCFD gas was designed to be used for artificial lift of nine inactive wells, and more than 7500 STB/D incremental oil was produced for all of the cases with the gas lift system.
- Different scenarios were studied through 12 cases. It was concluded that much greater annual income could be obtained by additional investment compared to the base case. Comparison of case 2 and 12 shows that if the initial increased investment is 159 million USD, incremental annual worth would increase 545 million USD.
- In most cases, payback period is less than 6 months and the invested money would be returned quickly. For instance, although the incremental capital costs of the case 12 are the highest, the payback period of this case is less than 4 months. The maximum value of annual worth (736.3 million USD) was obtained in this case.

Acknowledgements The authors thank other involved departments of Tarh-o-Palayesh Engineering Company for their kind collaboration in this paper.

Open Access This article is distributed under the terms of the Creative Commons Attribution 4.0 International License (<http://creativecommons.org/licenses/by/4.0/>), which permits unrestricted use, distribution, and reproduction in any medium, provided you give appropriate credit to the original author(s) and the source, provide a link to the Creative Commons license, and indicate if changes were made.

References

- Al-Jawad MS, Hassan OF. Correlating optimum stage pressure for sequential separator systems. *SPE Proj Facil Constr.* 2010;5(01):13–6. <https://doi.org/10.2118/118225-PA>.
- Al-Jawad MS, Hassan OF. Optimum separation pressure for heavy oils sequential separation. Paper presented at the Abu Dhabi

- International Petroleum Exhibition and Conference, Abu Dhabi. 2010b; <https://doi.org/10.2118/137995-MS>.
- Bahadori A, Vuthaluru HB, Mokhatab S. Optimizing separator pressures in the multistage crude oil production unit. *Asia-Pac J Chem Eng*. 2008;3(4):380–6. <https://doi.org/10.1002/apj.159>.
- Boyer BE, O'Connell S. Optimize separator operating pressures to reduce flash losses. Paper presented at the SPE/EPA/DOE Exploration and Production Environmental Conference, Texas. 2005; <https://doi.org/10.2118/94373-MS>.
- Brown KE. The technology of artificial lift methods, vol. 2. Tulsa: PPC Books; 1977.
- Cosentino L. Integrated reservoir studies. Paris: Editions Technip; 2001.
- Danesh A. PVT and phase behavior of petroleum reservoir fluids. *Developments in Petroleum Science*. 1998; 47.
- Eia U. Annual energy outlook. Washington, DC: US Energy Information Administration; 2017.
- Gilbert W. Flowing and gas-lift well performance. Paper presented at the Drilling and Production Practice. 1954.
- Global BP. BP Statistical Review of World Energy June 2017. Relatório. Disponível em: <http://www.bp.com/en/global/corporate/energy-economics/statistical-review-of-world-energy.html>, 2017.
- Gozalpour F, Ren SR, Tohidi B. CO₂ EOR and storage in oil reservoir. *Oil Gas Sci Technol*. 2005;60(3):537–46. <https://doi.org/10.2516/ogst.2005036>.
- Hassan OF. Prediction of optimum separation conditions for sequential field separation system. MSc thesis, University of Baghdad, Baghdad, Iraq (July 2004). 2004.
- Hodge J. Cycles and performance estimation, vol. 1. London: Academic Press; 1955.
- Hoffmann A, Stanko M. Short-term model-based production optimization of a surface production network with electric submersible pumps using piecewise-linear functions. *J Pet Sci Eng*. 2017;158:570–84. <https://doi.org/10.1016/j.petrol.2017.08.063>.
- Horlock J. Cogeneration—combined heat and power (CHP). Oxford: Pergamon Press; 1987.
- Horlock JH. Advanced gas turbine cycles: a brief review of power generation thermodynamics. Amsterdam: Elsevier; 2013.
- IPCC. Climate change 2001: the scientific basis. Cambridge: Cambridge University Press; 2001. p. 881.
- Jansohn P. Modern gas turbine systems: high efficiency, low emission, fuel flexible power generation. Amsterdam: Elsevier; 2013.
- Kerrebrock JL. Aircraft engines and gas turbines. Cambridge: MIT press; 1992.
- Khamukhin AA, Nikolayev EV. Modeling of gas multistage separation to increase stock tank oil. *Adv Mater Res*. 2014;1040:508–12. <https://doi.org/10.4028/www.scientific.net/AMR.1040.508>.
- Kim IH, Dan S, Kim H, Rim HR, Lee JM, Yoon ES. Simulation-based optimization of multistage separation process in offshore oil and gas production facilities. *Ind Eng Chem Res*. 2014;53(21):8810–20. <https://doi.org/10.1021/ie500403a>.
- Kylling ØW. Optimizing separator pressure in a multistage crude oil production plant. Trondheim: Norwegian University of Science and Technology; 2009.
- Li X, Ventura JA, Ayala LF. Carbon dioxide source selection and supply planning for fracking operations in shale gas and oil wells. *J Nat Gas Sci Eng*. 2018;55:74–88. <https://doi.org/10.1016/j.jngse.2018.04.014>.
- Ling K, Wu X, Guo B, He J. New method to estimate surface-separator optimum operating pressures. *Oil Gas Facil*. 2013;2(03):65–76. <https://doi.org/10.2118/163111-PA>.
- McCain WD. The properties of petroleum fluids. Tulsa: PennWell Books; 1990.
- McKee FE. Gas lift optimization. Patent Number U.S. 4,738,313. 1988.
- Miles J. Zero flaring can achieve operational, environmental benefits. *Oil Gas J*. 2001;99(30):72.
- Mohanty C, Adapala S, Meikap B. Removal of hazardous gaseous pollutants from industrial flue gases by a novel multi-stage fluidized bed desulfurizer. *J Hazard Mater*. 2009;165(1–3):427–34. <https://doi.org/10.1016/j.jhazmat.2008.10.044>.
- Mourad D, Ghazi O, Noureddine B. Recovery of flared gas through crude oil stabilization by a multi-staged separation with intermediate feeds: a case study. *Korean J Chem Eng*. 2009;26(6):1706–16. <https://doi.org/10.1007/s11814-009-0236-1>.
- Natco C-E. Technical development program. Houston: C-E Natco Company; 1972.
- Orangi A, Da Sie WJ, Prasanna VK, Zhang C, Bakshi A. Method and systems for integrated asset management utilizing multi-level modeling of oil field assets. Patent Number U.S. 11/505,163. 2008.
- Pan Z, Ye J, Zhou F, Tan Y, Connell LD, Fan J. CO₂ storage in coal to enhanced coal bed methane recovery: a review of field experiments in China. *Int Geol Rev*. 2018;60(5–6):754–76.
- Poettman FH, Carpenter PG. The multiphase flow of gas, oil, and water through vertical flow strings with application to the design of gas-lift installations. Paper presented at the Drilling and Production Practice, New York. 1952.
- Rahimpour M, Jamshidnejad Z, Jokar S, Karimi G, Ghorbani A, Mohammadi A. A comparative study of three different methods for flare gas recovery of Asalooey Gas Refinery. *J Nat Gas Sci Eng*. 2012;4:17–28. <https://doi.org/10.1016/j.jngse.2011.10.001>.
- Rahimpour M, Jokar SM. Feasibility of flare gas reformation to practical energy in Farashband gas refinery: no gas flaring. *J Hazard Mater*. 2012;209:204–17. <https://doi.org/10.1016/j.jhazmat.2012.01.017>.
- Rakhma T, Librawan R. Redesigning of process for determination of oil production facility operating conditions to increasing oil and gas production rates in Jambi Oilfield. Paper presented at the SPE Middle East Oil & Gas Show and Conference, Manama. 2015; <https://doi.org/10.2118/172710-MS>.
- Rubio E, Figurea L, Khan K, Davila R, Amro AAB, Tazerout K, et al. Integrated asset modeling unlocks reservoir deliverability and maximizes asset value in a Middle East Digital Oil Field. Paper presented at the SPE Abu Dhabi International Petroleum Exhibition and Conference, Abu Dhabi. 2017; <https://doi.org/10.2118/188723-MS>.
- Senani EG, Jahromi MG, Bairamzadeh S, Jahromi SG. Optimized production method in an oilfield laid South West of Iran: evaluation and selection. Conference Saint Petersburg. 2018; <http://doi.org/10.3997/2214-4609.201800149>.
- Shedid SA, Yakoot MS. Simulation study of technical and feasible gas lift performance. *Int J Pet Sci Technol*. 2016;10(1):21–44.
- Sinnott RK, Towler G. Chemical engineering design. SI Edition. Amsterdam: Elsevier; 2009.
- Soleimani M. Well performance optimization for gas lift operation in a heterogeneous reservoir by fine zonation and different well type integration. *J Nat Gas Sci Eng*. 2017;40:277–87.
- Walsh PP, Fletcher P. Gas turbine performance. New York: Wiley; 2004. <https://doi.org/10.1002/9780470774533>.